

# Appendix F: NWA Opportunity Evaluation Methodology

---

## Hawaiian Electric

### Non-Wires Opportunity Evaluation Methodology

March 2023 Update

# Contents

---

Appendix F: NWA Opportunity Evaluation Methodology.....	i
<b>1 Introduction.....</b>	<b>3</b>
1.1 Industry Survey.....	5
1.1.1 Industry Survey Findings.....	6
1.1.2 Stakeholder Feedback.....	9
1.2 T&D Non-Wires Alternatives.....	11
1.2.1 NWA Definition.....	11
1.2.2 NWA Grid Services.....	11
1.2.3 T&D Capacity Deferral.....	12
1.2.4 Distribution Reliability (Back-Tie).....	12
1.3 NWA Opportunity Evaluation Methodology.....	13
1.3.1 Overview.....	13
1.3.2 Opportunity Evaluation Methodology.....	14
1.4 Case Examples.....	24
1.4.1 Step 1: NWA Opportunity Screen.....	24
1.4.2 Step 2: NWA Opportunity Sourcing Evaluation.....	27
1.4.3 Step 3: Action Plan.....	32

# 1 Introduction

---

As it strives to provide 100 percent renewable energy by 2045, Hawaiian Electric (Company) faces a comprehensive transformation of our five electric power grids. Attaining our state’s renewable energy goals represents uncharted territory for both short-term and long-term resource planning. Performing the analyses necessary to attain this goal is a complicated resource planning process, requiring new tools and new processes. This report defines and explains the methodology involved in evaluating grid needs as possible non-wires alternatives opportunities. This process is essential to support the transformation to a clean energy future that leverages the continuous advancement in power technology.

The Company believes customers should have opportunities to deliver energy and other services to the electrical distribution system (commonly referred to as the distribution grid). In addition, the Company believes it should enable significant numbers of diverse providers to participate, and should facilitate competition to the benefit of all customers. By using a broad definition of distributed energy resources (DER), which include a variety of asset types, the Company is providing an increasing number of customers with the opportunity to participate in the DER marketplace. Expanding opportunities for DER services is essential to meeting renewable energy needs without sacrificing the reliable delivery of electricity, which customers deem a top priority.

This strategy is consistent with the Commission’s direction to fully and fairly consider non-transmission alternatives (NTA) and non-distribution alternatives (NDA), otherwise known as non-wires alternatives (NWA), when evaluating transmission and distribution (T&D) system upgrades.<sup>1</sup> The Commission also indicated that it will scrutinize whether NWA “solutions, regardless of ownership, are evaluated as part of any economic justification for new utility distribution system investment projects in the same fashion as it currently evaluates NTAs with respect to new transmission projects.”<sup>2</sup>

In 2019, the Commission reiterated its expectation that the distribution planning process “must transition and evolve accordingly, such that the locational benefits of customer-sited distributed energy resources are included and evaluated on a comparable basis as utility-sited NDAs as part of any economic justification for distribution system upgrades.<sup>3</sup> The Commission further directed the Company to “strive to make their non-wires alternatives analysis more transparent and thorough.”<sup>4</sup>

---

<sup>1</sup> HPUC Docket No. 2018-0055, Decision and Order No. 36288 Ka’aahi Substation, filed May 3, 2019, at 22.

<sup>2</sup> HPUC Docket No. 2015-0070, Decision and Order No. 33584, filed March 11, 2016, at 46.

<sup>3</sup> HPUC Docket No. 2018-0055, Decision and Order No. 36288 Ka’aahi Substation, filed May 3, 2019, at 22.

<sup>4</sup> HPUC Order No. 36725 Docket No. 2018-0165, Proceeding To Investigate Integrated Grid Planning, filed November 4, 2019, at 9.

Additionally, the Company is expanding options for broad DER participation necessary to grow a viable market, and for customers to directly benefit from competition. The Company's strategy is to offer a range of proven and innovative options to expand access for all customers—not just for a few.

This approach recognizes that the market for NWAs is nascent but represents a tangible opportunity for reducing customer costs and enabling a lower-carbon electricity grid.<sup>5</sup> As such, procurements may not fully enable a range of DER-based solutions. The Company's approach to NWAs specifically includes consideration of pricing through customer rates and programs in addition to procurement opportunities. This will enable customers to better manage their electricity use and provide grid services. As a result, the Company believes that customers, DER developers, and aggregators will have the potential to fully realize the value of DER for Hawai'i.

The Company has engaged, and will continue to engage, with customers and stakeholders to seek input and feedback on the Integrated Grid Planning (IGP) development and subsequent planning and sourcing. As part of the IGP development effort, the Distribution Planning Working Group (DPWG) is to inform and educate stakeholders on various aspects of distribution planning at the Company, and to afford stakeholders opportunities to collaborate on and co-develop the Company's methodologies to identify distribution grid needs as well as a framework to evaluate NWA opportunities. As described in the *Distribution Planning Methodology* report, grid needs will be identified through the distribution planning process and then evaluated for NWA opportunity suitability as discussed in this *Non-Wires Opportunity Evaluation Methodology* report.

The DPWG deliverables, as described in the IGP Workplan accepted by the Commission,<sup>6</sup> include identifying NWA opportunities and the related information requirements to effectively and efficiently procure and evaluate potential solutions. However, the need for an NWA opportunity evaluation methodology was not identified in the original IGP Workplan.<sup>7</sup> The Company and stakeholders subsequently recognized the need to incorporate a screening process, based on the leading industry practices and practical considerations, into the IGP and annual distribution planning cycles. This *Non-Wires Opportunity Evaluation Methodology* report addresses this additional scope and deliverable discussed by the DPWG.

Specifically, this *Non-Wires Opportunity Evaluation Methodology* report discusses the Company's industry survey and stakeholder feedback on best practices for NWA opportunity evaluation and sourcing, defines NWAs and grid services, presents the Company's NWA opportunity evaluation methodology, and provides case examples that the Company and stakeholders used to jointly validate the proposed NWA opportunity evaluation methodology. Two of the case examples were used in the Company's IGP Soft Launch, which was conducted to demonstrate the distribution planning process

---

<sup>5</sup> M. Dyson, J. Prince, et al., "The Non-Wires Solutions Implementation Playbook," Rocky Mountain Institute, 2018.

<sup>6</sup> HPUC Order No. 36218, Accepting the IGP Workplan and Providing Guidance, Docket No. 2018-0165.

<sup>7</sup> HECO, IGP Workplan, December 2018 filed December 14, 2018 in HPUC Docket No. 2018-0165  
[https://www.hawaiianelectric.com/documents/clean\\_energy\\_hawaii/integrated\\_grid\\_planning/dkt\\_20180165\\_20181214\\_igp\\_workplan.pdf](https://www.hawaiianelectric.com/documents/clean_energy_hawaii/integrated_grid_planning/dkt_20180165_20181214_igp_workplan.pdf).

from circuit-level load forecasting to solution evaluation to defer an actual capital investment to solve a grid need. The two examples used in the soft launch were the Ho`opili and East Kapolei cases, later described in Section 5.3. Through that effort, the Company gained invaluable experience that will help improve the full-scale IGP planning and sourcing effort. This report reflects a key milestone in the Company's efforts to comply with the Commission's guidance regarding systematic and transparent consideration of NWAs, leveraging industry best practices, and stakeholder engagement.<sup>8</sup>

**March 2023 update.** This Non-Wires Opportunity Evaluation Methodology is being submitted with the IGP Grid Needs Assessment and Solution Evaluation Methodology (Dkt. No. 2018-0165, dated March 31, 2023) and supersedes previously filed versions. This update incorporates the Company's learnings from recent NWA activities, as well as discussions with the IGP TAP. Notable updates include 1) additional definition to the NWA sourcing evaluation (Section 1.3.2) to classify whether potential solutions are considered favorable, moderate, or unfavorable across the various dimensions, and 2) additional case examples of experiences with the NWA process (Section 1.4).

## 1.1 Industry Survey

---

In 2019, the Company engaged the Pacific Energy Institute to conduct an industry survey<sup>9</sup> of best practices for NWA opportunity evaluation and sourcing in seven states (including California, Connecticut, Hawaii, Maine, New Hampshire, New York, and Rhode Island) as well as to review documents prepared by several organizations, including Rocky Mountain Institute (RMI),<sup>10</sup> Northeast Energy Efficiency Partnerships,<sup>11</sup> Smart Electric Power Alliance (SEPA),<sup>12</sup> and ICF.<sup>13</sup> Additionally, an NWA workshop was held on March 26, 2019,<sup>14</sup> where the Company sought to learn from experienced practitioners (that is, utility and DER solution providers). The industry survey findings are summarized in Section 2.1.

The Company also held 10 stakeholder working group meetings in 2019 where stakeholders discussed NWA services definitions, distribution grid needs identification, NWA opportunity evaluation, and information requirements. Stakeholder feedback is summarized in Section 2.2.

---

<sup>8</sup> HPUC Order No. 33584, Maui Elec. Co., Ltd., Docket No. 2015-0070, filed March 11, 2016, at 45-46, and HPUC Order No. 36288, Ka'aahi Substation application, Docket No. 2018-0055, at 22-25.

<sup>9</sup> P. De Martini and A. De Martini, NWA Opportunity Evaluation Survey of Current Practice, Pacific Energy Institute, March 2020.

<sup>10</sup> M. Dyson, J. Prince, et al., "The Non-Wires Solutions Implementation Playbook," Rocky Mountain Institute, 2018..

<sup>11</sup> Northeast Energy Efficiency Partnerships, State Leadership Driving Non-Wires Alternatives Projects and Policy, 2017.

<sup>12</sup> SEPA, PLMA and E4The Future, Non-Wires Alternatives: Case Studies From Leading U.S. Projects, November 2018.

<sup>13</sup> ICF presentation in Michigan PSC workshop, June 2019  
[https://www.michigan.gov/documents/mpsc/062719\\_PDF\\_Presentations\\_660616\\_7.pdf](https://www.michigan.gov/documents/mpsc/062719_PDF_Presentations_660616_7.pdf)

<sup>14</sup> IGP Soft Launch WG Meeting speaker presentations:  
[https://www.hawaiianelectric.com/documents/clean\\_energy\\_hawaii/integrated\\_grid\\_planning/stakeholder\\_engagement/working\\_groups/soft\\_launch/20190326\\_igp\\_soft\\_launch\\_wg\\_meeting\\_presentation\\_materials.pdf](https://www.hawaiianelectric.com/documents/clean_energy_hawaii/integrated_grid_planning/stakeholder_engagement/working_groups/soft_launch/20190326_igp_soft_launch_wg_meeting_presentation_materials.pdf)

## 1.1.1 Industry Survey Findings

Based on the industry survey and observations of industry analysts, the use of NWAs for distribution grid needs is at an early stage. The industry is still learning and refining approaches to improve on the early mixed success to-date.<sup>15</sup> However, commonalities are emerging from these early states' and utilities' lessons learned that provide valuable insights for Hawai'i's success.

The Company has considered the following key findings from this survey in the development of its NWA opportunity evaluation process:

The NWA opportunity evaluation should be integrated into standard, open, and transparent utility planning processes to encourage the effective engagement of market participants to best meet regulatory and utility-level objectives.<sup>16</sup>

Traditional (T&D) planning processes can better support NWA solutions if screening criteria are used to determine when alternatives should be considered for a given need.

Information should be shared with stakeholders regarding an NWA opportunity, including engineering analysis, performance requirements, and other data needed to assess the opportunity.

Evaluation of opportunities is done on a technology agnostic, comparable basis as part of the economic justification for distribution system upgrades.<sup>17</sup>

Evaluation processes focus on identifying high-confidence recommendations for DER solicitations that are likely to result in successful, cost-effective investment deferrals.<sup>18</sup>

NWA opportunities to date have initially addressed grid needs for capacity increases.

Reliability, voltage/reactive power, and resilience have been identified for future consideration.

The type of T&D need, time frame for in-service date, and reference T&D project cost are common criteria used by all states surveyed to evaluate NWA opportunities.

Not all T&D capital projects are suited for an NWA opportunity. T&D capital projects involving break-fix, outage replacements, aging infrastructure replacement, infrastructure relocation, or customer service connections should be excluded.

Procurements may not be best suited for all NWA opportunities (for example, smaller value projects and/or reaching certain customer classes), instead other programmatic options may be considered, such as:

---

<sup>15</sup> Reported California initial NWA procurement results and ICF 2019.

<sup>16</sup> M. Dyson, J. Prince, et al., "The Non-Wires Solutions Implementation Playbook," Rocky Mountain Institute, 2018 and SEPA, PLMA and E4The Future, 2018.

<sup>17</sup> HPUC Order No. 36725 Docket No. 2018-0165, Proceeding To Investigate Integrated Grid Planning.

<sup>18</sup> CPUC Decision on the Distribution Investment and Deferral Process (D.18-02-004).

Targeted energy efficiency (EE)/demand-side management programs are employed.

DER services tariffs are under discussion in a few states.

States and utilities should first consider no-cost (capital) operational options (for example, circuit reconfiguration and phase balancing) as well as low-cost grid technology alternatives (for example, sensing and analytics, and power flow controllers) as an alternative to traditional capital projects.

Additionally, the survey identified several themes regarding the evaluation criteria. As noted above, the type of T&D need, timing for in-service date, and reference T&D project cost are common criteria. The type of grid needs and the related performance requirements are considered. The timing for in-service includes consideration of the procurement/program development process, regulatory approval, and implementation timelines. Project cost is based on the capital cost of the traditional wires project.

However, the application of these criteria differs among states and utilities. The states in the Northeast have clearly defined the types of T&D projects that are suitable for NWA opportunities and have defined minimum thresholds for timing and project cost. These minimums have been developed through stakeholder discussions and consideration of the timing in that state. An example is provided in Figure F-1.

**Figure F-1: National Grid’s New York NWA Opportunity Evaluation Criteria**

Criteria	Potential Elements Addressed	
Project Type Suitability	Project types include Load Relief and Reliability. Other types have minimal suitability and will be reviewed as suitability changes due to State policy or technological changes.	
Timeline Suitability	Large Project	36-60 months
	Small Project	18-24 months
Cost Suitability	Large Project	Greater than or equal to \$1M
	Small Project	Greater than or equal to \$500K

Source: National Grid 2017

Like New York, as shown in Figure F-1, California also employs these three criteria and adds two: forecast uncertainty of timing and scope, and market assessment. California’s evaluation is focused on whether an NWA procurement should be pursued and uses a tiered prioritization approach to identify the ripest opportunities (Tier 1), opportunities that may be less certain (Tier 2), and opportunities that are not suitable for NWAs (Tier 3). This is illustrated in the Southern California Edison (SCE) example in Figure F-2. As seen in other states, California utilities each have their own version of the criteria and a slightly different prioritization tier structure.

**Figure F-2: SCE NWA Opportunity Prioritization**

Tier	Project	Cost Effective	Forecast Certainty	Market Assessment
1	Nogales 66/12 (D)	Green	Green	Green
	Lockheed 66/16 (D)	Green	Orange	Green
	Sun City 115/12	Green	Yellow	Yellow
	Mira Loma 66/12 (D)	Yellow	Green	Yellow
2	Newhall 66/16 (D)	Yellow	Green	Green
	Crater 66/16 (D)	Green	Orange	Green
	MacArthur 66/12 (D)	Green	Yellow	Yellow
	Mariposa 66/12 (D)	Orange	Green	Yellow
	Moorpark 'A' 220/66 (S)	Orange	Green	Orange
	Saugus 'C' 220/66 (S)	Yellow	Orange	Orange
	Elizabeth Lake 66/16 (D)	Yellow	Orange	Yellow
	Elizabeth Lake 66/16 (D)	Yellow	Orange	Yellow
3	Vera 66/12 (D)	Orange	Yellow	Green
	Hathaway 66/12	Orange	Green	Green
	Rector 220/66 (S)	Yellow	Yellow	Orange
	Springville 220/66 (S)	Orange	Yellow	Yellow
	Garnet 115/33 (D)	Yellow	Green	Orange
	Lindsay 66/12 (D)	Orange	Orange	Orange
	Live Oak 66/12 (D)	Orange	Yellow	Orange
	Mira Loma 220/66 (S)	Orange	Green	Orange

The California NWA evaluation methodology offers useful additional criteria to evaluate opportunities as compared to the states in the Northeast. However, the California methodology is overly complex in its attempt to quantify the metrics. In practice, California’s prioritization is effectively based on a smaller set of factors similar to the northeastern states.<sup>19</sup> That is, the T&D grid need requirements (including timing), related grid service, and project-related avoided cost were used to determine whether a procurement makes sense. The California process is also singularly focused on evaluating procurement opportunities, so it does not consider alternative sourcing options, such as programs.

The Company does think the use of the California metrics for forecast certainty and market assessment are useful in the context of considering alternative NWA sourcing options involving programs and pricing, or reconsideration of procurement at a later date.

Based on the insights drawn from the industry survey and practitioners, simplicity and flexibility appear to be important considerations in developing NWA opportunity evaluation criteria. Simplicity is important in terms of the ability to implement a fair and repeatable process, and to provide clarity to the market. Flexibility is important in terms of allowing opportunities to pursue viable NWAs through sourcing means other than all-or-nothing procurements. For example, consideration should be given to the role that programmatic options may provide for opportunities that might otherwise not make sense economically for a procurement. The Company has incorporated these findings into its approach.

<sup>19</sup> See [https://www.pge.com/en\\_US/for-our-business-partners/energy-supply/electric-rfo/wholesale-electric-power-procurement/2019-didf-rfo.page?ctx=large-business](https://www.pge.com/en_US/for-our-business-partners/energy-supply/electric-rfo/wholesale-electric-power-procurement/2019-didf-rfo.page?ctx=large-business)



## 1.1.2 Stakeholder Feedback

As mentioned at the beginning of Section 2, the Company held 10 stakeholder working group meetings in 2019 where stakeholders discussed NWA services definitions, distribution grid needs identification, NWA opportunity evaluation, and information requirements. These discussions included the findings from the industry survey and NWA workshop, discussed in Section 2.1. This stakeholder engagement also included using specific grid needs in Ho’opili and East Kapolei as case examples to shape the IGP Soft Launch.

Importantly, these discussions considered the development of the IGP methodology to identify and assess NWA opportunities as a key step in the handoff from grid needs to NWA sourcing (for example, procurements and programs). Stakeholders’ input and feedback is reflected in the NWA opportunity evaluation process and criteria. The stakeholder feedback received in the DPWG and Soft Launch working group meetings is summarized in the following sections.<sup>20</sup>

The Company also presented the NWA Methodology along with more detailed evaluation threshold criteria and additional sample evaluations to the Technical Advisory Panel (TAP) on November 16, 2022 and received generally positive feedback.

### 1.1.2.1 Overall Process

Stakeholders shared that the NWA opportunity evaluation process needs to be transparent and less restrictive with respect to screening criteria at this initial stage in Hawai’i to open up the potential market for procurements. Stakeholders also shared that a technology agnostic approach to assessing opportunities is needed and that it is important to not prejudge what the market may provide.

Stakeholders support consideration of other sourcing mechanisms beyond procurement (programs, tariffs) and flexibility in sourcing to achieve the most cost-effective outcome. This includes the potential to participate in multiple non-conflicting grid services opportunities. Additionally, the IGP process should continue to reassess projects in subsequent planning cycles that are initially assessed as uncertain because of the constant changing nature of the distribution system. The T&D grid needs and NWA opportunity evaluations and supporting analysis should be shared publicly as part of the IGP process.

### 1.1.2.2 Defining Grid Needs

The output of the distribution planning process is a set of grid needs. Stakeholders should have sufficient information on these needs to consider potential solutions and understand the application of the evaluation criteria. This includes technical performance requirements, including quantity (MW, MWh), dispatch frequency and time (month/day/hour), duration, and in-service date. The supporting engineering analysis, and a description and technical details of the wires solution are also desired (for

---

<sup>20</sup> Drawn from DPWG minutes: <https://www.hawaiianelectric.com/clean-energy-hawaii/integrated-grid-planning/stakeholder-engagement/working-groups/distribution-planning-and-grid-services-documents>

example, information on type of infrastructure location, timing, and avoided cost). Stakeholders suggested simplifying the requirements to the extent possible to allow for more potential NWA solutions.

### 1.1.2.3 Opportunity Criteria

Stakeholders appreciate the simplicity of the three-criteria approach used by the states in the Northeast but also like aspects of the California prioritization model. Stakeholders suggested using clearly defined metrics for minimum timing for in-service date and project economics criteria for procurements, as follows:

- Timing: in-service date – minimum of 2 years to provide enough time to run a procurement and regulatory process, and install NWAs
- Project economics: minimum of \$1 million capital project cost threshold for NWA procurements

Stakeholders also suggested consideration of greenhouse gas emissions reductions and other societal criteria (for example, community impact) in prioritizing NWA opportunities. The question of whether to consider greenhouse gas emissions was not resolved in the working group discussion, but stakeholders recognized that greenhouse gas benefits are important, but not necessary, for NWA opportunity sourcing evaluation. Stakeholders suggested that NWA societal value considerations may be better suited to evaluating the specific proposed NWA solutions resulting from procurements/programs as is done in New York. The recommendation is for this issue to be taken up in the Solution Evaluation and Optimization Working Group.

### 1.1.2.4 Sourcing Options

Stakeholders noted that across the industry, NWAs have largely not been successful thus far. Stakeholders recognize that procurements are one type of NWA sourcing mechanism and that programs and pricing options should be considered as well. A programmatic approach that looks to fulfill more global power system needs was suggested. Programs also may be easier for customers to understand. Stakeholders agree that an NWA program, as with procurements, must be cost-effective for all customers.

During the Soft Launch discussion regarding Ho’opili, stakeholders recognized the NWA procurement challenge for new real estate developments: that NWA solutions may need to be sited and ready to go at the same time the house is built. Stakeholders suggested that a programmatic approach (including EE and other DER) through the collaboration of the real estate developer and the Company may be the best option.

Additionally, stakeholders seek to maximize the potential participation opportunities for NWAs and grid services in the aggregate. For example, a stakeholder shared that a \$50,000 per year NWA opportunity may not be worth a procurement or program, but it may have potential after being aggregated with other potential grid services opportunities.

## 1.2 T&D Non-Wires Alternatives

---

The definitions of NWA and grid services presented in this section, including the specific wording for each of the terms, are derived from the industry research and stakeholder input and feedback discussed in Section 2.

### 1.2.1 NWA Definition

NWAs generally are non-traditional solutions that may defer, delay, or avoid traditional T&D investments (for example, a new substation or feeder). Non-traditional solutions can include a single solution or a combination of solutions at the grid-scale or distribution level, such as solar photovoltaic (PV), other renewable generation, energy storage, EE, and demand response (including price responsive demand). The following NWA definition was developed in concert with the DPWG:

*An electricity grid project that uses non-traditional transmission and distribution (T&D) solutions, such as distributed generation (DG), energy storage, energy efficiency (EE), demand response (DR), and grid software and controls, to defer or avoid the need for conventional transmission and/or distribution infrastructure investments.*

This definition adapts several aspects developed by Navigant,<sup>21</sup> the US Department of Energy,<sup>22</sup> and others.<sup>23</sup>

### 1.2.2 NWA Grid Services

A wide range of grid services are needed as Hawai'i decarbonizes the electricity sector with ultimately more than half its resources at the edge of the system. Already, DERs have the opportunity to provide bulk system ancillary services, including frequency response, replacement reserves, and regulation on a technology agnostic basis.<sup>24</sup> Additionally, in support of the IGP planning cycle and Commission direction,<sup>25</sup> the Company has identified and defined initial T&D NWA services in technology agnostic terms, building on the work developed for the Demand Response portfolio in Docket No. 2015-0412. An example of where the Company will apply the NWA evaluation process are the projects identified through the distribution planning process, as described in the *Distribution Planning Methodology* report. Using the outline detailed in this report, these projects are candidates to be evaluated for NWA opportunity.

Specifically, these initial NWA services are focused on those with the greatest potential value involving T&D capital deferral services (for example, distribution capacity deferral and reliability services). Capital

---

<sup>21</sup> B. Feldman, Non-Wires Alternatives: What's up next in utility business model evolution, UtilityDive, July 12, 2017.

<sup>22</sup> Electricity Advisory Committee, Recommendations on Non-Wires Solutions, US Department of Energy, October 17, 2012.

<sup>23</sup> SEPA, PLMA & E4TheFuture, "Non-wires Alternatives: Case Studies from Leading US Projects", 2018.

<sup>24</sup> See Docket No. 2015-0412, Decision and Order No. 35238, issued on January 25, 2018.

<sup>25</sup> HPUC Order No. 33584, Maui Elec. Co., Ltd., Docket No. 2015-0070, filed March 11, 2016, at 45-46.

deferral is the primary focus of the Federal Energy Regulatory Commission for transmission<sup>26</sup> and the leading states' use for distribution, as found in the industry survey discussed in Section 2.

The service descriptions and definitions in Sections 3.2.1 and 3.2.2 are based on IGP stakeholder input and feedback leveraging references from California's Competitive Solicitation Working Group.<sup>27</sup>

### 1.2.3 T&D Capacity Deferral

T&D capacity deferral opportunities involve the potential to defer capital investment that may otherwise be needed to address grid needs that are identified through area capacity analysis and/or hosting capacity analysis. This may include deferring substations, new lines/reconductoring, transformers, and other equipment by reducing forecast loading of the infrastructure to within ampacity/load ratings under normal operating conditions. Loading in this context relates to the current and/or power (bi-directional) carrying capability of specific conductor, transformer, and/or other equipment. Therefore, increases in forecast loading may arise from new loads and/or energy injections from distributed resources (that is, reverse power flow).

The following definition of T&D capacity service was developed with the DPWG to describe these types of opportunities:

*A supply and/or a load modifying service that DERs provide as required via reduction or increase of power or load that is capable of reliably and consistently reducing net loading<sup>28</sup> on desired transmission and/or distribution infrastructure. T&D capacity service can be provided by a single DER and/or an aggregated set of DERs that reduce the net loading on a specific distribution infrastructure location coincident with the identified operational need in response to a control signal from the utility.*

This definition combines both NTAs and NDAs into a single service in recognition of the potential to yield optimized benefits across T&D opportunities from NWA solutions.

### 1.2.4 Distribution Reliability (Back-Tie)

In addition to NWA opportunities under normal grid operating conditions, there are potential opportunities under contingent conditions. Contingent operating conditions involve emergency reconfigurations of the distribution system that result in transferring the load (that is, bi-directional current/power) from one circuit/transformer to another to mitigate an outage. These contingent opportunities arise when combined loading exceeds the emergency ampacity/power rating of the conductor, transformer, and/or other equipment. This is a reliability-oriented service because it enables

---

<sup>26</sup> E. Watson and K. Colburn, Looking Beyond Transmission, Public Utilities Fortnightly, April 2013.

<sup>27</sup> California Competitive Solicitations Framework Working Group <https://drpwg.org/sample-page/ider/>.

<sup>28</sup> Net loading refers to the net amount of bi-direction current on specific grid infrastructure.

safe transfer of one circuit/transformer's load to another during an emergency by creating sufficient headroom or reducing the transferring load to within emergency ratings.

The following definition of distribution reliability service was developed in the DPWG:

*A supply and/or load modifying service capable of improving local distribution reliability under abnormal conditions. Specifically, this service reduces contingent loading of grid infrastructure to enable operational flexibility to safely and reliably reconfigure the distribution system to restore customers.*

This type of distribution service is relatively new in the industry; the Company's procurement for this service in the IGP Soft Launch was one of the first, if not the first. In a future IGP cycle, the Company may evaluate a wider set of T&D NWA services. For example, voltage support and resiliency services may be identified and defined through the process of documenting the T&D needs and services requirements. Resiliency services are currently being discussed in the Resiliency Working Group and through Docket No. 2018-0163, which is intended to produce a Microgrid Services Tariff.

## 1.3 NWA Opportunity Evaluation Methodology

---

### 1.3.1 Overview

The Company has considered the NWA opportunity evaluation approaches and lessons learned from other states as well as stakeholder feedback to develop a holistic methodology. The multi-state lessons and stakeholder feedback support RMI's recommendation that *"traditional planning processes can better support non-wires solutions if screening criteria are used to determine when alternatives should be considered for a given need."*<sup>29</sup>

The Company intends to use such a common NWA opportunity evaluation framework to identify T&D projects that are most likely to be suitable for NWA solutions. This evaluation methodology is intended to provide greater clarity, certainty, and transparency to the market going forward. Such criteria incorporated into the IGP process will also facilitate systematic consideration of NWAs by T&D planners going forward as directed by the Commission. The goals of this NWA opportunity evaluation methodology are as follows:

- Identify all potential candidate T&D projects that may be cost-effectively deferred through the identified and defined DER services.
- Productively engage the market for NWAs by helping DER aggregators and developers efficiently allocate resources to the best opportunities.

---

<sup>29</sup> M. Dyson, J. Prince, et al., "The Non-Wires Solutions Implementation Playbook", Rocky Mountain Institute, 2018.

Further, Commission guidance and stakeholder feedback outlined the following objectives in the development of an NWA opportunity evaluation framework:

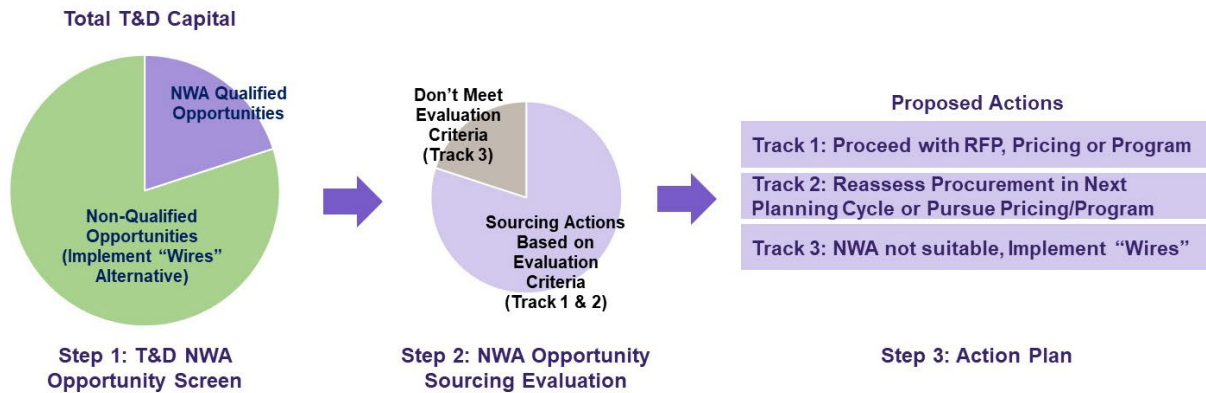
- Adopt/adapt leading practices to develop candidate T&D NWA opportunity evaluation.
- During initial NWA opportunity screens, create over-inclusive, rather than overly restrictive, candidate NWA project shortlists.
- Use a simple initial NWA opportunity screen to identify shortlist candidate opportunities and assess sourcing options (procurement, programs, and pricing).
- Remember that not all NWA opportunities make economic sense to source via competitive procurement. Therefore, price signals through rate design and DER programs will also be considered to achieve the most affordable solutions for customers.

These goals and objectives shaped the development of the NWA opportunity evaluation methodology described in Section 4.2. The Company believes that this opportunity screen and prioritization approach will support development of an NWA market. Recognizing that NWA procurements and use are at a relatively nascent stage of implementation across the industry, the Company expects this evaluation methodology to evolve as the industry collectively gains more NWA experience. This NWA opportunity evaluation methodology is not meant to be an NWA solution evaluation as would be done in a procurement; rather this is an assessment of the potential T&D projects that qualify for an NWA opportunity.

### 1.3.2 Opportunity Evaluation Methodology

The Company has developed a three-step methodology that incorporates 1) an initial NWA opportunity screen, 2) an NWA opportunity sourcing evaluation and 3) an action plan. The initial opportunity screen is intended to quickly and simply identify “qualified” and “non-qualified” T&D opportunities based on technical requirements. The opportunity sourcing evaluation in the second step further evaluates and prioritizes the “qualified” opportunities in terms of the grid project avoided cost (economics), timing of need, and performance requirements to support a procurement. This three-step approach, shown in Figure F-3, is based on leading practices from states in the Northeast and from California as well as stakeholder feedback tailored to Hawai‘i’s needs.

**Figure F-3: NWA Opportunity Evaluation Methodology**



This methodology is designed to identify a wider set of potential NWA opportunities than methodologies in other states. Step 1 does not include a dollar threshold, unlike the states in the Northeast; instead, program or pricing options may be considered viable in the Step 2 evaluation. The incorporation of program and pricing options in the Step 2 sourcing evaluation is for those opportunities considered too financially small for procurement. Step 2 methodology also includes a clearly defined minimum dollar threshold for procurements identified by stakeholders that is similar in approach to that of the states in the Northeast. This is a more transparent method than the overly complex California approach<sup>30,31</sup> that also effectively uses the project capital avoided cost as the primary economic threshold. The resulting T&D action plan in Step 3 is intended to enable a range of potential NWA sourcing options via procurement, programs, and pricing consistent with another RMI recommendation.<sup>32</sup>

### 1.3.2.1 Step 1: NWA Opportunity Screen

The intent of the NWA opportunity screen is to categorize all T&D capital budget projects by applying a technical screen and to identify those T&D projects that are most suitable for further NWA opportunity evaluation. As discussed with stakeholders and identified by other states, certain T&D projects with the greatest NWA opportunity include the following three grid needs categories:

1. Expanding distribution system capacity to meet load and/or hosting capacity needs (that is, new substation, new feeders, reconductoring)
2. Ensuring a reliability requirement for circuit back-tie upgrade deferral
3. Enhancing system resilience<sup>33</sup>

<sup>30</sup> Pacific Gas & Electric, Request for Approval to Issue Competitive Solicitations for Distributed Energy Resource (DER) Procurement for Electric Distribution Deferral Opportunities. November 15, 2019. CPUC Advice Letter 5688-E.

<sup>31</sup> Southern California Edison, Southern California Edison Company's Request for Approval to Launch the 2020 Distribution Investment Deferral Framework, November 15, 2019 Solicitation. CPUC Advice Letter 4108-E.

<sup>32</sup> M. Dyson, J. Prince, et al., "The Non-Wires Solutions Implementation Playbook", Rocky Mountain Institute, 2018, page 39.

<sup>33</sup> Reliability scoped to be redundant, such as a second feeder and its associated infrastructure, would be qualified opportunities. However, hardening, or physically strengthening critical infrastructure, would not be considered a qualified opportunity.



As the Company has identified in the IGP, consistent with best industry practices, these types of T&D needs may be met by new NWA grid services, including T&D capacity deferral service, reliability back-tie service, and resiliency service. The Soft Launch pursued procurement of distribution capacity deferral and reliability back-tie services. The Company's reliability back-tie service is a first for the industry. These three types of T&D needs will form the initial screen.

Conversely, certain T&D projects cannot, or are unlikely to, be deferred or avoided by DER. These "required" projects include those necessary to comply with public works or other customer requests, such as the following:

- Line/pole relocation or undergrounding due to street widening, relocation clauses, or overhead-to-underground conversions
- Emergency and preventative equipment and infrastructure replacement to restore power after outages, avoid outages, avoid catastrophic failures, and ensure public safety
- Replacement of physical apparatus, such as circuit breakers, relays, and transformers, because of asset condition
- Replacement of damaged or failed equipment/poles/conductor
- New customer requests for new physical connection to the electric grid

The Step 1 screen will categorize all T&D opportunities in the Company's capital budget into two groups based on the project type:

- T&D projects with an NWA opportunity involving one or more of the three grid needs categories described earlier in this section.
- T&D projects that address "required" needs outside of the three NWA opportunity categories. This step can be done in conjunction with the Company's annual capital budgeting process to ensure that consistency is applied across the enterprise. Those T&D projects identified as required in this initial screen will be pursued as utility wires solutions in the appropriate regulatory approval procedure (that is, general rate case or a cost recovery mechanism such as a GO7 application).

Focusing on the most viable NWAs by categorizing opportunities by these specific capital project types is employed in every state currently pursuing NWAs.

### **1.3.2.2 Step 2: NWA Opportunity Sourcing Evaluation**

The Company, through the use of NWAs, seeks to expand options for broad participation in support of growing a viable DER market to meet Hawai'i's goals. It is also important for all customers to directly benefit from the use of DER. As such, the Company's approach is to consider a range of competitive market-based procurement, program, and pricing options to expand access for all customers—not just for a few. This approach is different than what California and other states consider in their NWA procurement-focused opportunity evaluations.



While the Company's methodology adapts aspects of California's<sup>34</sup> evaluation criteria, it is done here in the context of assessing other sourcing options, such as programs and retail pricing, as well as procurements on the basis of favorable, uncertain, or unfavorable attributes. The implied precision of California's complex quantitative approach, in practice, does not identify more NWA procurement opportunities than the simpler methods employed in other states. Based on the six mainland states surveyed, NWA opportunities for procurement averaged approximately 1 to 2 percent of all T&D capital projects<sup>35</sup> and about 5 to 10 percent of initially screened distribution upgrade projects.<sup>36</sup>

The Company is adapting elements of the California approach as such elements are useful in considering sourcing options other than procurements. Therefore, the intent of this second step is to evaluate candidate T&D NWA opportunities in greater detail to identify those with the highest likelihood of success and related solution sourcing options. This NWA opportunity sourcing evaluation is technology agnostic, consistent with the Company's IGP process.

The following three criteria is used to evaluate NWA opportunities:

- **Timing** of the grid need
- **Performance requirements** in relation to operational performance requirements of the identified T&D grid need
- **Project economics** in terms of the deferral value of a qualified T&D capital project and any other relevant avoided costs to determine sourcing options

The following criteria were considered to evaluate NWA opportunities but is currently not included in the evaluation due to lack of quality market data, and to broaden the NWA opportunities that can move to Step 3. These criteria may be reassessed with further NWA experience and market responses to future RFPs.

- **Forecast certainty** of the forecasted growth driving the grid need
- **Market assessment** based on the potential for successful NWA procurement versus programs or retail pricing options in the immediate local area related to the grid need

Each grid project will be assessed in relative terms within each criterion. The criteria are further explained below.

## Timing

Timing of the grid need is an important factor. Sufficient lead time is required to allow for a procurement (including contract negotiations) or program development, regulatory approval, and NWA solution deployment by the in-service date, as required by the forecasted operational date, to meet the

---

<sup>34</sup> California PUC Decision on the Distribution Investment and Deferral Process (D.18-02-004).

<sup>35</sup> California utilities' distribution deferral opportunities reports for 2018 and 2019 are consistent with this finding.

<sup>36</sup> P. De Martini and A. De Martini, NWA Opportunity Evaluation Survey of Current Practice, Pacific Energy Institute, March 2020

grid need. Based on the Company's experience with sourcing other grid services, and consistent with stakeholder feedback and industry practice, a starting point of a 2-year lead time is used.

One lesson learned from the industry survey was that the time needed for NWA procurement contract negotiations and subsequent regulatory approval are key factors in the time required. In addition, depending on the complexity of the contingent wires solution in the event the NWA sourcing does not yield a viable solution, more lead time may be needed. The minimum timing threshold may be adjusted as the Company, the market, and the Commission learn from future NWA opportunities.

Timing criteria are defined as follows:

**Favorable:**

- 2-5 year lead time

**Moderate or Uncertain:**

- Greater than 5 year lead time

**Unfavorable:**

- Less than 2 year lead time

Grid needs with lead times greater than 5 years are considered Moderate or Uncertain and will be reassessed during the next IGP cycle.

## Performance Requirements

The performance requirements criterion will be used to determine whether NWA solutions can reasonably meet the performance requirements of the identified grid need (capacity expansion, reliability back-tie, or resiliency). Projects that target critical needs with high operational risks are more likely to require more stringent performance requirements and contract terms for NWA solutions. In general, opportunities with more lenient requirements are more viable for NWAs. For example, if the opportunity has a smaller peak capacity, shorter duration needs, and fewer calls, then the ability to meet the performance requirements will be considered more favorable for an NWA.

Performance criteria are defined as follows:

**Favorable:**

- Capacity: Up to 5 MW and
- Duration: Up to 4 hours

**Moderate or Uncertain:**

- Capacity: > 5 MW and < 10 MW or
- Duration: > 4 hours and < 8 hours

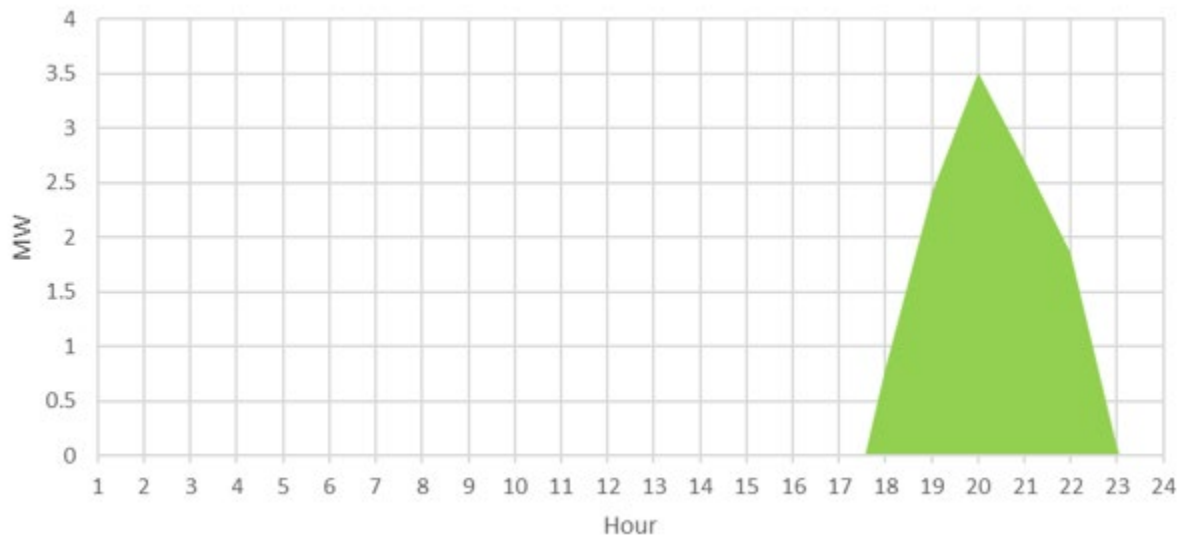
**Unfavorable:**

- Capacity: 10 MW and larger
- Duration: 8 hours or more

The grid need will be clearly described as illustrated in Figure F-4, along with supporting engineering and operational analyses as provided in the Soft Launch<sup>37</sup> and case examples<sup>38</sup> discussed with the DPWG in August and October 2019.

**Figure F-4: Example Engineering Analysis and Performance Requirements**

### Projected Hourly Needs Summary



Equipment	MW Peak	MWH	Delivery Months	Delivery Hours	Duration (Hr)	Max # of Days
Tsf/Circuit	3.5	11.4	Jan - Dec	5PM - 11PM	6	365

These performance requirements are intended to provide as complete a picture as possible of the grid need and operational performance required of solutions to transparently inform stakeholders.

### Project Economics

The project economics criterion will be used to evaluate opportunities for procurement, programs, and/or pricing, and to identify opportunities that are unlikely to be cost-effective. The project economics include the deferral value of a qualified T&D capital project and any other relevant avoided costs. Based on stakeholder feedback, projects with an economic value (that is, capital cost) of \$1 million or greater will be seen as favorable in this criteria. Projects with an economic value less than \$1

<sup>37</sup> DPWG Meeting August 8, 2019 “Review of Soft Launch Opportunity” presentation: [https://www.hawaiianelectric.com/documents/clean\\_energy\\_hawaii/integrated\\_grid\\_planning/stakeholder\\_engagement/working\\_groups/distribution\\_planning/20190808\\_dpwg\\_meeting\\_presentation\\_materials.pdf](https://www.hawaiianelectric.com/documents/clean_energy_hawaii/integrated_grid_planning/stakeholder_engagement/working_groups/distribution_planning/20190808_dpwg_meeting_presentation_materials.pdf).

<sup>38</sup> DPWG Meeting October 9, 2019 “Review of T&D NWA Opportunity Identification & Evaluation Process” presentation: [https://www.hawaiianelectric.com/documents/clean\\_energy\\_hawaii/integrated\\_grid\\_planning/stakeholder\\_engagement/working\\_groups/distribution\\_planning/20191009\\_dpwg\\_meeting\\_presentation\\_materials.pdf](https://www.hawaiianelectric.com/documents/clean_energy_hawaii/integrated_grid_planning/stakeholder_engagement/working_groups/distribution_planning/20191009_dpwg_meeting_presentation_materials.pdf).

million may be considered for targeted DER programs to address specific NWA needs consistent with the Company's Advanced Rate Design Strategy.<sup>39</sup>

Project Economic criteria are defined as follows:

**Favorable:** \$1M and above

**Moderate or Uncertain:** Between \$500K and \$1M

**Unfavorable:** Less than \$500K

## Forecast Certainty

Forecast certainty criterion is important to avoid investment in grid needs that may be premature or not required if the forecasted load growth does not materialize. However, this forecast certainty criterion is currently not used to evaluate grid needs because the Company has yet to determine the evaluation metrics for this. The Company may consider qualitative factors in the future such as, but not limited to, the following:

- **Favorable:** If the forecasted load growth is driven by actual electric service requests received, which may signal higher certainty of developer plans driving a grid need.
- **Moderate or Uncertain:**
  - If the forecasted load growth is driven by conceptual or high-level master plans, which may signal moderate certainty of developer plans.
  - If the forecasted load growth is driven by spatial allocation of the Company system-wide growth forecast, which may signal moderate certainty of growth in an area.

## Market Assessment

The market assessment criterion is used to assess the following two aspects in terms of procurement/program sourcing options:

- Technical potential based on the number of customers available for behind-the-meter solutions and land availability for ahead-of-the-meter solutions
- Supplier and solution diversity to ensure competitiveness and reliability

The opportunity for a DER-based alternative is dependent on sufficient existing or new customers and/or land availability in the appropriate locations associated with the circuits and/or substation(s) to develop an NWA solution sufficient to meet an identified grid need. Also, as procurements are intended to foster competitive solutions, it is beneficial to identify whether sufficient customers and/or land opportunity exists to support competitive proposals from more than one provider. These factors may be used to evaluate the potential success of an NWA procurement/program and any mitigation

---

<sup>39</sup> Hawaiian Electric Companies, Advanced Rate Design Strategy, September 25, 2019.

[https://www.hawaiianelectric.com/documents/clean\\_energy\\_hawaii/grid\\_modernization/dkt\\_2018\\_0141\\_20190925\\_cos\\_ARDS.pdf](https://www.hawaiianelectric.com/documents/clean_energy_hawaii/grid_modernization/dkt_2018_0141_20190925_cos_ARDS.pdf)

measures that may be needed to realize a successful outcome for customers. For instance, as proposed by stakeholders, an NWA program may provide a better outcome for a new residential development than a procurement.<sup>40</sup>

However, currently the Company lacks quality market data to properly assess this criteria. Therefore this criteria is not used in this evaluation. This criteria may be reassessed based on market response to future RFPs.

### 1.3.2.3 Step 3: Action Plan

The NWA opportunity sourcing evaluation discussed in Section 4.2.2 results in a T&D action plan that assigns specific T&D projects to one of three action plan tracks. The assigned action plan track will provide the path the Company will use to pursue a solution. Competitive procurement is the primary means of sourcing opportunities \$1 million or greater. However, based on stakeholder discussion in the DPWG, the Company sought to expand the potential for NWAs by including the option for programs and pricing for opportunities under \$1 million and for those opportunities that do not lend themselves to procurement, such as new real estate developments. As such, this sourcing approach adapts the California model by explicitly incorporating the option for programs and pricing options in Track 2 to expand the potential for NWA solutions for grid needs less than \$1 million in economic value.<sup>41</sup> The three tracks are as follows:

- **Track 1:** Procurement of favorable NWA opportunities (that is, greater than \$1 million in economic value with in-service need in 2 to 5 years) with performance requirements that can reasonably be met by NWAs.
- **Track 2:** Reassess if factors indicate reevaluating in the future for potential procurement (that is, moderate/uncertain or favorable performance and economic criteria and timing greater than 5 years); or a program or pricing if the economic value is less than \$1 million but greater than \$500K and potential timing of need is favorable (2 to 5 years) for customer adoption.
- **Track 3:** Non-qualified opportunities that have criteria (for example, performance, timing, or economics) that cannot be reasonably met by NWA solutions. In these instances, the wires solution will be implemented.

The action plan will include a summary list of T&D project opportunities evaluated and the proposed course of action on solutions for each grid need. In addition, the supporting evaluation for each NWA opportunity will be discussed.

---

<sup>40</sup> Stakeholder comments on programmatic approach for NWA in DPWG meetings beginning in July 17, 2019 meeting: [https://www.hawaiianelectric.com/documents/clean\\_energy\\_hawaii/integrated\\_grid\\_planning/stakeholder\\_engagement/working\\_groups/distribution\\_planning/20190717\\_dpwg\\_meeting\\_summary\\_notes.pdf](https://www.hawaiianelectric.com/documents/clean_energy_hawaii/integrated_grid_planning/stakeholder_engagement/working_groups/distribution_planning/20190717_dpwg_meeting_summary_notes.pdf)

<sup>41</sup> Note that in the Northeast and California, the utilities employ demand side management programs funded by existing customer public surcharges to mitigate grid needs before pursuing NWA procurements.

**Figure F-5: T&D NWA Opportunity Evaluation**

Track	Timing	Overall Performance	Economics
1	<b>Favorable</b>	<b>Favorable</b> or <b>Moderate/Uncertain</b>	<b>Favorable</b>
2 (Pricing)	<b>Favorable</b>	<b>Favorable</b> or <b>Moderate/Uncertain</b>	<b>Moderate/Uncertain</b>
2 (Reassess)	<b>Moderate/Uncertain</b>	<b>Favorable</b> or <b>Moderate/Uncertain</b>	
3	One or more are <b>Unfavorable</b>		

Figure F-5 identifies potential distribution opportunities in one of the three tracks described above, along with a corresponding color code—green (favorable), yellow (uncertain), and red (unfavorable)—to highlight the assessment of each criterion to indicate why the opportunity was placed into the given track.

### 1.3.2.4 Contingency Plan

The primary goal of action plans Track 1 and Track 2, as mentioned in section 4.2.3, is to pursue successful deferral of the grid project with a NWA. However, for the Company to meet its obligation to provide electric service, there may be a need to develop a contingency plan based on grid investment or another alternative to ensure that the in-service date and lead time to implement those solutions may be met.

During NWA procurement and/or program implementation, solicitation/program development, NWA deployment/customer adoption, or NWA commercial operation, several scenarios may occur that could cause the NWA solution to not viably solve the grid need. For example, if there are no cost-effective NWA bids that meet the distribution need, or if contracts are not approved by the Commission, implementation of the Company’s contingency solution will be needed. This contingency solution may include the wires project originally intended for deferral. For this reason, it will be necessary to continue preliminary engineering solution development activity, such as wires project engineering and other related activity. This challenge was discussed with the IGP TAP on November 16, 2022,<sup>42</sup> which the TAP suggested the Company also assess the risk of a non-performing NWA, and the impact should be considered in identifying NWA opportunities.

As the NWA process and market mature, a framework may need to be developed that covers contingency planning for NWAs similar to what has been developed for competitive bidding of

<sup>42</sup> See [https://www.hawaiianelectric.com/documents/clean\\_energy\\_hawaii/integrated\\_grid\\_planning/stakeholder\\_engagement/technical\\_advisory\\_panel/20221116\\_tap\\_feedback.pdf](https://www.hawaiianelectric.com/documents/clean_energy_hawaii/integrated_grid_planning/stakeholder_engagement/technical_advisory_panel/20221116_tap_feedback.pdf)

generation.<sup>43</sup> As part of the Competitive Procurement Working Group within the IGP process, the Company is revising the competitive bidding framework to cover procurement of NWAs. Modifications to contingency planning will be covered by those revisions as well as processes and procedures to facilitate the procurement of NWAs.

If NWA bids meet most of the distribution need, but not all of the need required for a full deferral, the Company may develop short lead time mitigation alternatives that supplement the NWA portfolio for the total solution where feasible. Depending on how early in the procurement process the shortcoming is known and the amount that will be insufficient, the Company may initially attempt to use NWAs as a contingency measure to supplement the deficiency or may consider smaller wires solutions and/or operational constraints to temporarily remedy a deficiency. If a cost-effective solution does not exist, the Company may need to pursue the contingency plan's alternative solution. This may include operating solutions, up to pursuing the initial traditional solution. For example, if an NWA solution can resolve a distribution line overload, but the location leaves a portion unmitigated, that smaller remaining portion may still be reconducted to supplement the NWA solution. Such contingency solutions may require the Company to seek expedited approval by the Commission.

If the NWA provider is unable to install NWAs according to the contract, the Company may develop short lead time mitigation alternatives that supplement the NWA portfolio for the total solution where feasible in accordance to the wire solutions development<sup>44</sup> steps. The supplemental solution would be the least complex solution that addresses the shortcoming. This could include an operating solution, like switching, that uses existing equipment or load balancing. If a cost-effective NWA mitigation solution does not exist, the Company may pursue the contingency solution.

If the NWA fails during field commissioning or underperforms during operations based on commissioning and performance verification protocols agreed to in the contract, the Company will determine emergency limitations, if applicable, and will work with system operations on potential grid reconfiguration or load drop for all scenarios above. The Company will determine the reason for NWA underperformance, assess any equipment damage or outage impacts, assess whether new mitigation is required, and determine expedited solution options. If issues such as these arise and result in adverse impacts on reliability (that is, system average interruption duration index and system average interruption frequency index metrics), then any associated impacts on performance incentives/penalties must also be considered.

The absolute latest a decision can be made for a distribution project intended for deferral is directly after final design is complete and before the scheduling, permitting, and construction of the project begins. This varies depending on the project being deferred, but typically distribution projects that do not require permitting require a project commencement decision to be made at least 12 to 48 months

---

<sup>43</sup> See, Decision and Order No. 23131 filed on December 9, 2006 in Docket No. 03-0372, Instituting a Proceeding to Investigate Competitive Bidding for New Generating Capacity in Hawaii. Available at, <http://files.hawaii.gov/dcca/dca/dno/dno2006/23121.pdf>

<sup>44</sup> See the *Distribution Planning Methodology* report, Section 6.



prior to the need date (as described in the *Distribution Planning Methodology* report, Section 5.3). The timing of the contingency decision process may change over time as the Company continues to understand the impact of scheduling traditional and DER solutions in parallel.

Cost recovery of preliminary engineering costs for contingency solutions is another issue that may need to be raised with the Commission in the future. The Company acknowledges that the issue of preliminary engineering costs that are expended to produce contingency or parallel plans to third-party contracted NWA services may be discussed in the performance-based regulation proceeding as part of the discussion on adjustments to the major project interim recovery mechanism.

## 1.4 Case Examples

---

The Company shared several identified grid needs with stakeholders at the October 9, 2019, DPWG meeting for the purpose of jointly validating the proposed NWA opportunity evaluation methodology with real examples.<sup>45</sup> These real T&D projects have been identified and scoped by the Company for consideration. These illustrative projects were discussed with stakeholders to refine the NWA opportunity evaluation methodology and to jointly assess each opportunity. For this reason, a representative set of examples that includes projects that are typically screened out of NWA consideration in California and the Northeast were included for the DPWG discussion. As such, this list is not the complete list of potential grid projects, nor does it represent a final list of evaluated NWA opportunities as is found in the California Distribution Deferral Opportunity Report, for example. However, the results of the DPWG's feedback and application of this methodology in the Soft Launch and in the DPWG meetings is consistent with the California and Northeast approaches to identifying viable NWA opportunities for procurement.<sup>46</sup> The following includes example projects discussed during the October 9, 2019 DPWG meeting<sup>47</sup>. Additional example projects discussed during the November 2022 TAP presentation<sup>48</sup> on the NWA opportunity evaluation process are also included.

### 1.4.1 Step 1: NWA Opportunity Screen

Several case example T&D projects were discussed with stakeholders. The projects presented in this section are examples of capital projects that do not represent viable NWA opportunities and, as such, would be screened out in Step 1 of the process. The projects that passed Step 1 screening are discussed under Step 2 in Section 5.2.

---

<sup>45</sup> October 9, 2019, DPWG meeting presentation, see slides 19-54

[https://www.hawaiianelectric.com/documents/clean\\_energy\\_hawaii/integrated\\_grid\\_planning/stakeholder\\_engagement/working\\_groups/distribution\\_planning/20191009\\_dpwg\\_meeting\\_presentation\\_materials.pdf](https://www.hawaiianelectric.com/documents/clean_energy_hawaii/integrated_grid_planning/stakeholder_engagement/working_groups/distribution_planning/20191009_dpwg_meeting_presentation_materials.pdf).

<sup>46</sup> Note: In 2019, PG&E and SCE identified a combined total of over 800 grid needs that were screened to only 10 projects (6 for SCE and 4 for PG&E) for NWA procurement. This is consistent with the experience in the Northeast.

<sup>47</sup> October 9, 2019, DPWG Meeting Summary Notes

[https://www.hawaiianelectric.com/documents/clean\\_energy\\_hawaii/integrated\\_grid\\_planning/stakeholder\\_engagement/working\\_groups/distribution\\_planning/20191009\\_dpwg\\_meeting\\_summary\\_notes.pdf](https://www.hawaiianelectric.com/documents/clean_energy_hawaii/integrated_grid_planning/stakeholder_engagement/working_groups/distribution_planning/20191009_dpwg_meeting_summary_notes.pdf).

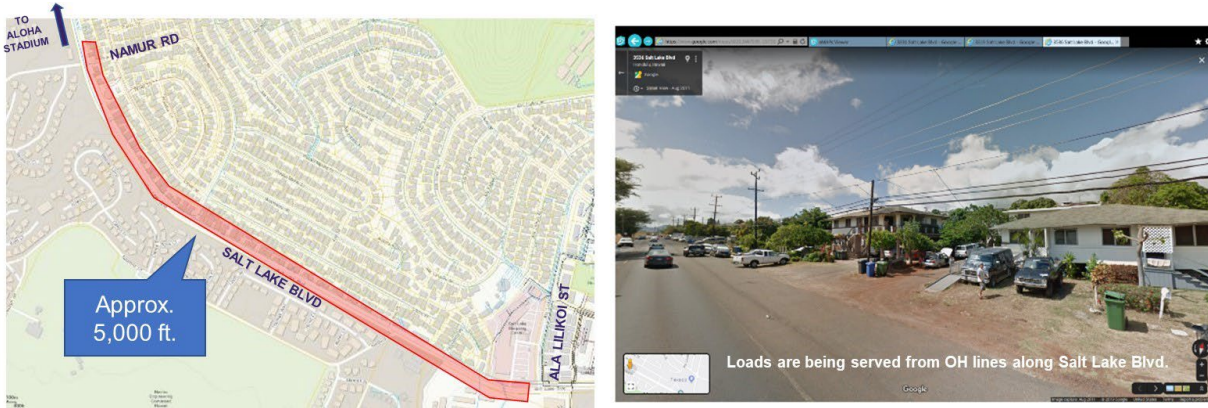
<sup>48</sup> November 16, 2022, DPWG Meeting Summary Notes [IGP Technical Advisory Panel Distribution Grid Needs Assessment & Non-Wires Alternatives \(hawaiianelectric.com\)](https://www.hawaiianelectric.com/documents/clean_energy_hawaii/integrated_grid_planning/stakeholder_engagement/working_groups/distribution_planning/20221116_tap_presentation_materials.pdf)



### 1.4.1.1 Salt Lake Boulevard Overhead Line Relocation

This project involved an overhead (OH) to underground (UG) line conversion and relocation of Salt Lake Boulevard OH lines requested by public works, as illustrated in Figure F-6.

Figure F-6: Salt Lake Boulevard Overhead Line Relocation

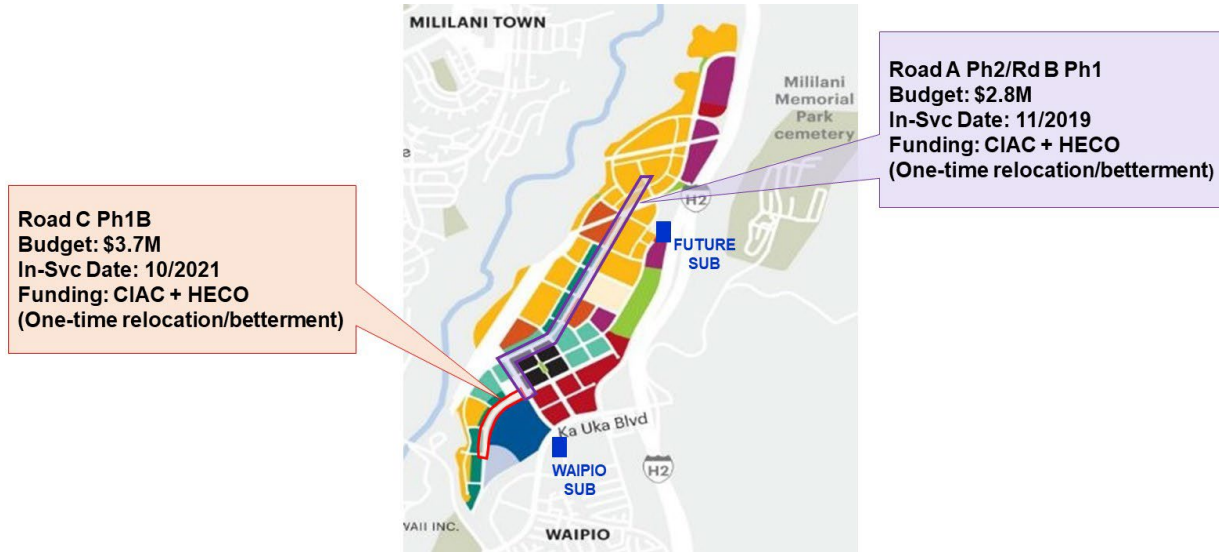


This project involved relocating a portion of an existing line; therefore, the alternative is to remove that line. This means that downstream loads would need to be removed from the grid. Stakeholder consensus in the meeting was that this type of project is not a feasible NWA opportunity. This type of project requested by public works would be put into the non-qualified category in Step 1.

### 1.4.1.2 Wai'au-Mililani 46 kV OH to UG Conversion

A customer requested OH to UG conversion projects for betterment in support of the Koa Ridge Development, as shown in Figure F-7. The scope of work includes installation of OH transitions and UG electrical facilities and then removal of existing OH electrical facilities once UG facilities are energized. The total project cost is \$6.5 million, with the developer contributing the majority of the funding through contributions in aid of construction (CIAC). The Company's cost after the customer's contributions is about \$800,000. In-service dates vary between 2020 and 2021.

Figure F-7: Waiiau-Mililani 46 kV OH to UG Conversion



Stakeholders agreed that this type of customer-requested betterment OH to UG conversion project is not a feasible NWA opportunity. Customer-requested betterment conversion projects will be put into the non-qualified category in Step 1.

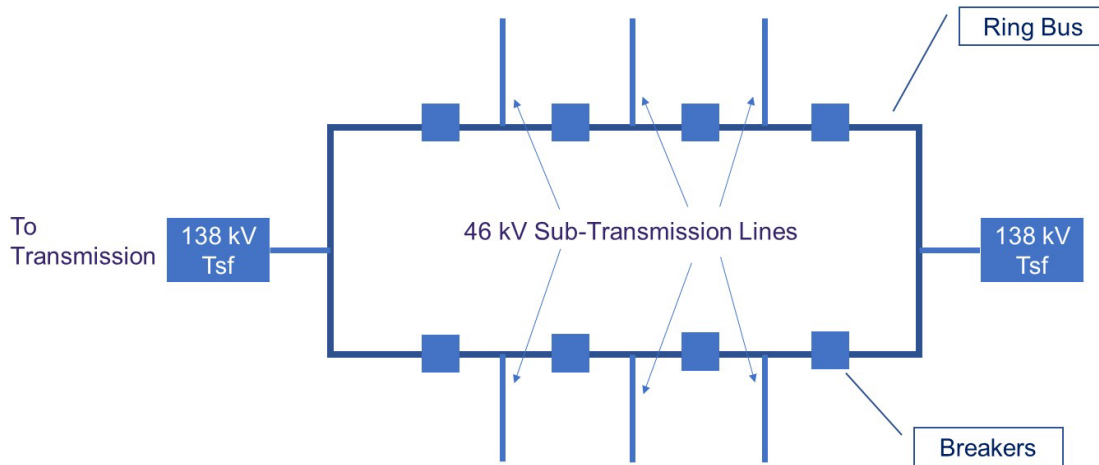
#### 1.4.1.3 Waiiau 46 kV GIS Bus Replacement

This project is proposed to replace the existing deteriorated 46 kV air-insulated switchyard with a new 46 kV gas-insulated substation (GIS). This major 46 kV switching station provides service to Waiiau, Ewa, Mililani, Pearl City, and Waipahu through eight sub-transmission lines with a total bus load (2018) of 92 MW. Findings from Black & Veatch's *Waiiau 46 kV Substation Engineering Study* dated 2013 are as follows:

- Substation that is well beyond its design life (66+ years in marine environment)
- Bus configuration that creates risk of major outage and is expensive to operate
- Severely corroded steel structure
- Inadequate grounding system creating potential hazard to public
- Aged, obsolete, and unreliable equipment providing unreliable service
- Inadequate housing for modern protective relays

The scope of work includes installing a new 46 kV GIS ring bus (circuit breakers are connected to form a ring, with isolators on both sides of each breaker) and constructing a new 46 kV control house, with provisions for future 138 kV relays, as shown in Figure F-8. The estimated project cost is \$60 million to \$80 million, with an in-service date of September 2024.

Figure F-8: Waiiau 46 kV GIS Bus



Stakeholder consensus was that this type of aging infrastructure project is not an NWA opportunity because there is not a viable approach to avoid the ring bus and breaker replacement. Also, the 46 kV substation bus provides system benefits by allowing renewable projects and DER to export renewable energy to other parts of the grid in support of Hawai'i's 100 percent renewable objective. As such, this project would be screened out in Step 1.

The three example projects screened out in Step 1, which include line relocation, line OH to UG conversion, or bus replacement of aging infrastructure, represent projects where the alternative is to remove that section of the line or bus. This means that downstream loads would either result in losing a backup source or need to be removed from the grid.

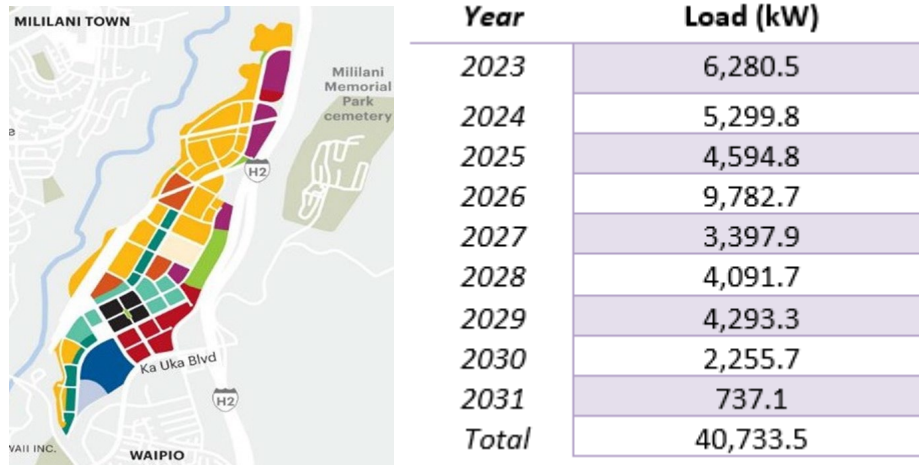
## 1.4.2 Step 2: NWA Opportunity Sourcing Evaluation

The following case example T&D projects that passed Step 1 screening were discussed with the IGP Technical Advisory Panel on November 16, 2022 in the joint application of the Step 2 evaluation criteria.

### 1.4.2.1 Koa Ridge

Koa Ridge Development in Central O'ahu near Mililani, built by Castle & Cooke Hawai'i, includes 3,500 new homes, a medical center, commercial and light industrial development, parks, and schools. The developer estimated an additional 40.7 MW of load at the completion of the development. Additional distribution capacity would be needed by 2025 to address the new development growth, as shown in Figure F-9.

**Figure F-9: Waipio Substation and Koa Ridge Load Forecast**



The load growth will result in an overload of substation transformers under normal and emergency conditions, as presented and discussed with the stakeholders.

The proposed wires T&D project is to install a 10 MVA 46-12 kV transformer and associated equipment at Waipio Substation with an estimated cost of \$2.9 million, with an in-service date of 2025.

The Koa Ridge project is categorized as an expansion of distribution system capacity in Step 1. The following is the assessment for Step 2:

- Performance Requirements: Performance requirements are a potential challenge given the long-duration and high-magnitude overloads, and given the results of the Soft Launch (see Section 5.3) it is uncertain if a procurement will be successful (red).
- Timing: The in-service date is more than 2 years away (Green).
- Economic Assessment: The T&D project cost is greater than \$1 million (Green).

Transformer	Timing	Overall Performance	Economics
Waipio 1 (Normal, Base)	2025	<ul style="list-style-type: none"> <li>• Capacity: 10.6 MW</li> <li>• Duration: 23 hours</li> <li>• 365 calls per year</li> </ul>	\$ 2.9M
Waipio 1 (N-1, Base)	2025	<ul style="list-style-type: none"> <li>• Capacity: 11.5 MW</li> <li>• Duration: 14 hours</li> <li>• 365 calls per year</li> </ul>	\$ 2.9M

Due to the large performance needs to address the projected overloads with capacity needs greater than 10 MW and duration longer than 8 hours, this Koa Ridge project’s overall performance needs is deemed to be unfavorable and placed into Track 3 which indicates a non-qualified NWA opportunity that cannot be reasonably met by NWA solutions and the wires solution is to be implemented.

### 1.4.2.2 CEIP 46 Sub-transmission Circuit Reconductoring

The CEIP 46 sub-transmission system serves a large portion of mid-west O’ahu from Ewa to Kapolei. It also serves as the backup in contingency scenarios to the Kahe, Ewa Nui, and Waiau sub-transmission systems. See Appendix A for map of the service area. There are a number of new loads forecasted to be served from the CEIP 46 sub-transmission system. The load for these projects total approximately 53 MW of new load growth. Additional distribution capacity would be needed by 2025 to address the load growth.

The proposed T&D project is to reconductor a section of the CEIP 46 sub-transmission circuit and associated equipment at an estimated cost of \$3.93 million, with an in-service date of 2025

The load growth will result in an contingency overload of the current carrying capacity of the cable/conductor. This project is categorized as ensuring a reliability requirement for circuit back-tie upgrade deferral in Step 1. The following is the assessment for Step 2:

- Performance Requirements: Performance requirements are considered favorable given a potential challenge given its short-duration and low-magnitude overloads (Green).
- Timing: The in-service date is more than 2 years away (Green).
- Economic Assessment: The T&D project cost is greater than \$1 million (Green).

Transformer	Timing	Overall Performance	Economics
CEIP/CEIP 46 (N-1)	2025	<ul style="list-style-type: none"> <li>• Capacity: 4.7 MW</li> <li>• Duration: 3 hours</li> <li>• 14 calls per year</li> </ul>	\$ 3.9M

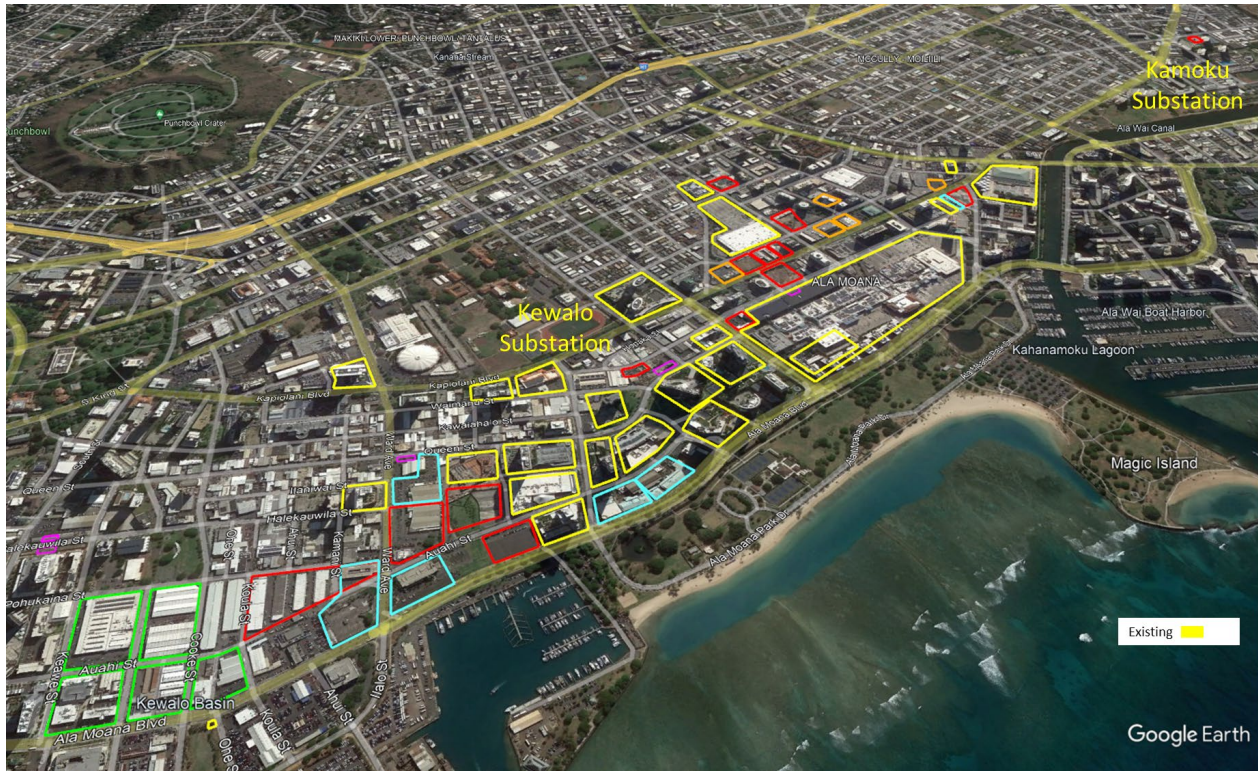
Due to all evaluation criteria being favorable this project is placed into Track 1.

### 1.4.2.3 Kakaako and Ala Moana Development Areas

New residential/commercial projects have been proposed in the Kakaako and Ala Moana area due to the Transit-Oriented Development (TOD) Special District Design Guidelines, which promote “intense and efficient use of land” near the rail stations, as shown in Figure F-10. The Company received six TOD-related service requests in the Ala Moana area, and two more appeared to be in development per news reports and feedback from the City. The Ala Moana TOD need was previously identified as a Track 2 opportunity because the performance requirements and timing were uncertain. The opportunity would be reconsidered in the next planning cycle based on further information on the need, including refinement of performance requirements, timing of in-service date(s), and scoping and estimation of a wires solution. Since then, several projects have not materialized and the refinement of the forecast shows more growth in the Kakaako area instead.

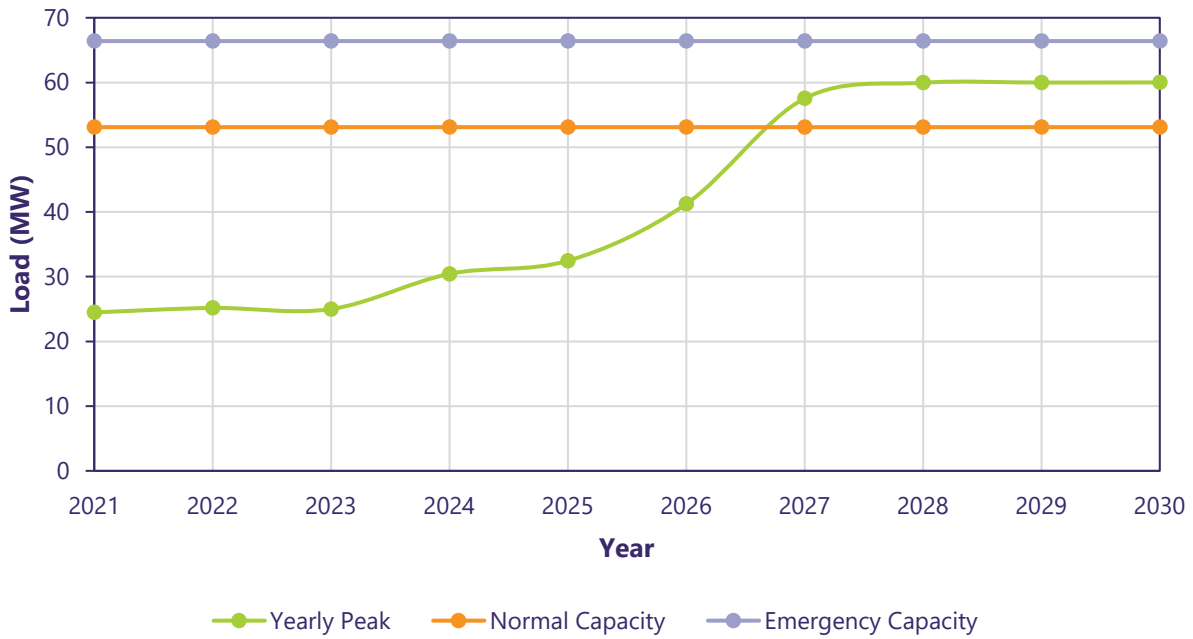


Figure F-10: Kakaako and Ala Moana Area

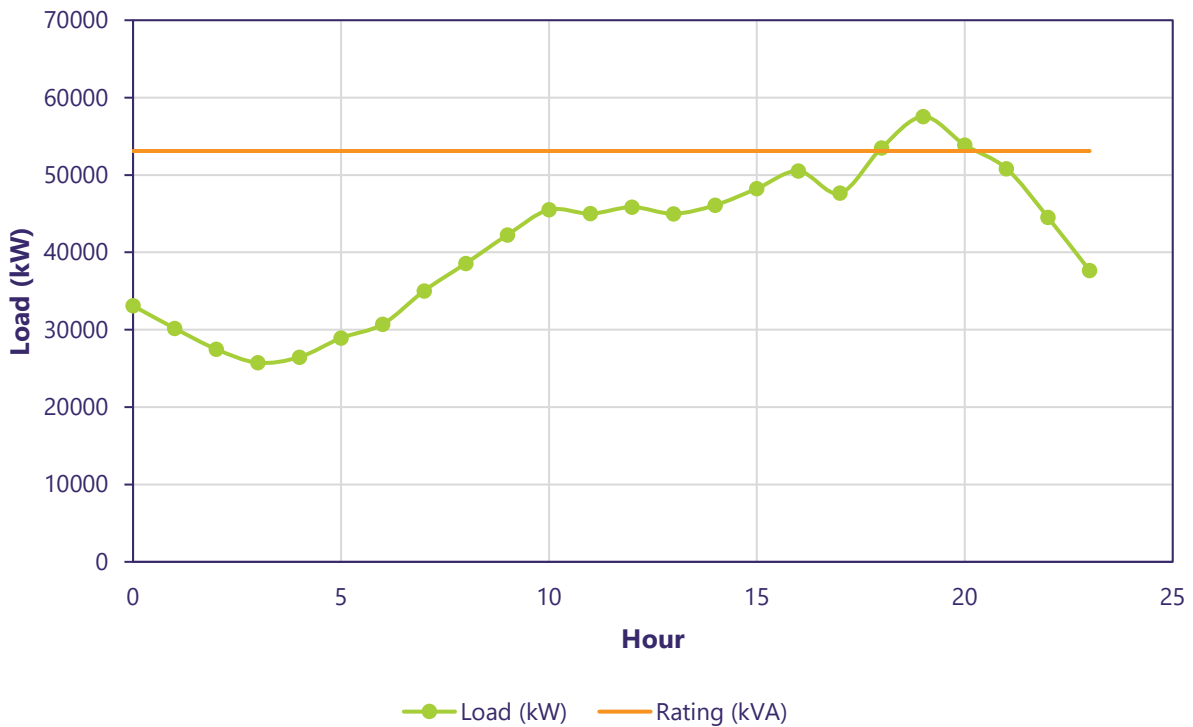


The Kakaako area under development is focused between Kamakee Street and Keawe Street and is served by a 25 kV distribution system fed by the Kewalo Substation (in Kakaako), Kamoku Substation (near Iolani School), and /or Iwilei Substation. With the projected loads based on service requests and developer plans, overloads will occur as illustrated in Figure F-11 and Figure F-12.

**Figure F-11: Kewalo T3 Yearly Peak Forecast**



**Figure F-12: Kewalo T3 2027 Peak Day Overload**



The proposed wires T&D project is to install a 50 MVA 138-25 kV transformer at Kewalo Substation and extend new circuits to the Kakaako development area at an estimated cost of \$22 million, with an in-service date of 2026.

The Kewalo T3 project is a qualified NWA opportunity based on the Step 1 criteria. The project is considered expansion of the distribution system capacity.

The following is the assessment from Step 2:

- Performance Requirements: Transformer loading requirements are favorable (Green).
- Timing: The in-service date is more than 2 years away (Green).
- Economic Assessment: The T&D project cost is greater than \$1 million (Green).

Transformer	Timing	Overall Performance	Economics
Kewalo T3 (Normal, Base)	2027	<ul style="list-style-type: none"> <li>• Capacity: 4.43 MW</li> <li>• Duration: 3 hours</li> <li>• 12 calls per year</li> </ul>	\$ 22M

Based on the evaluation criteria this project is placed into Track 1.

### 1.4.3 Step 3: Action Plan

The following are example steps the Company took to seek NWA solutions for projects that were placed in Track 1. The Company conducted a Soft Launch and several Expression of Interests (EOI) to demonstrate the grid needs assessment, NWA opportunity evaluation, sourcing process, and solution evaluation methods for NWAs by using real-world examples. These examples also allowed the Company to gain experience identifying needs for resource choices while being subjected to an evaluation and construction time line. The lessons learned in the Soft Launch and EOIs are being used to help inform development of the full-scale IGP planning and sourcing effort.

#### 1.4.3.1 IGP Soft Launch RFP – Ho’opili and East Kapolei Area

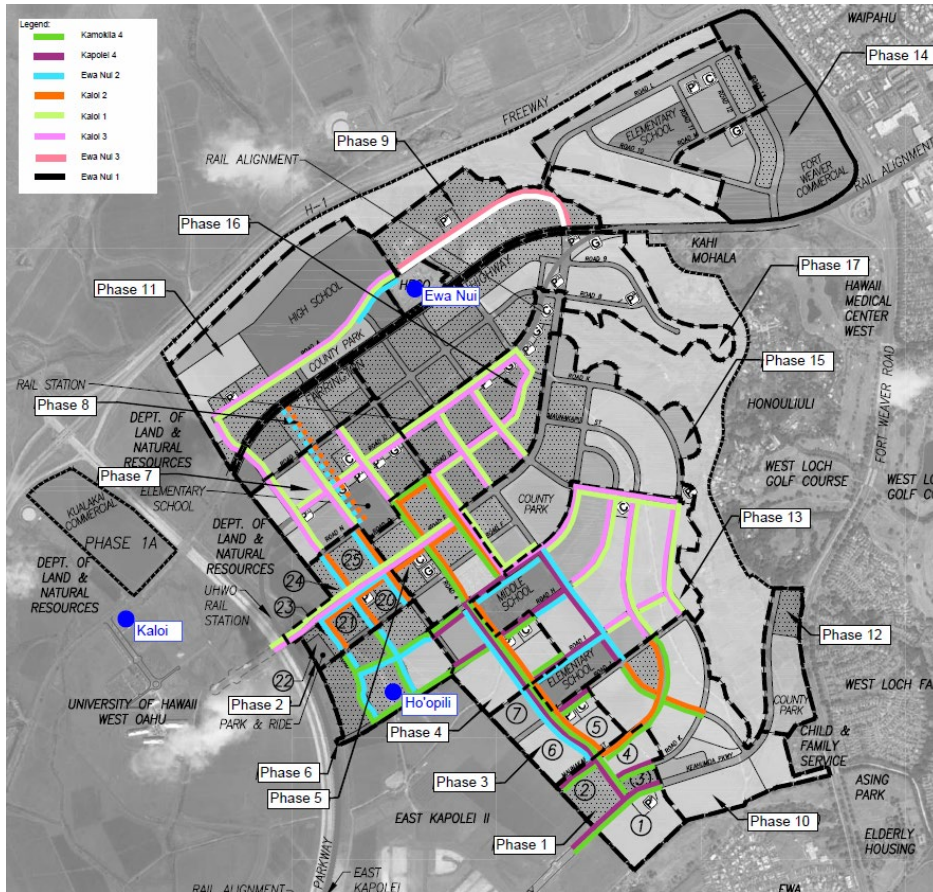
The Company identified two T&D NWA opportunities to source through a competitive procurement as part of the IGP Soft Launch. These two opportunities were effectively identified as Track 1 opportunities to pursue for procurement. The following discussion summarizes the opportunities and results.

Ho’opili is a mixed-use master-planned community developed by D.R. Horton in west O’ahu located north of Ewa Beach and east of Kapolei, as shown in Figure F-13. The plans for this new community include 11,750 new residential homes, 7 community and recreation centers, over 200 acres of commercial farms and community gardens, up to 3 million square feet of commercial space, and 5 Department of Education public schools. In addition to Ho’opili, there are currently over 20 additional customer service requests in the area with completion dates within the next few years. Due to an



estimated load growth of 83.4 MWA, overloads under contingency conditions are forecasted to occur in 2022, with normal overload conditions beginning in 2023.

**Figure F-13: Planned Ho’opili Development**



The load growth will result in an overload of substation transformers and distribution circuits under normal and emergency conditions, as shown in Figures F-14 and F-15. From these overloads, two NWA opportunities were identified. The first NWA opportunity was to defer the Kapolei 4 Circuit Extension project with a commercial operation date (COD) of February 1, 2022. The second NWA opportunity was to defer the Ho’opili Substation project with a COD of January 1, 2023.

**Figure F-14: Summary of Normal Overloads**

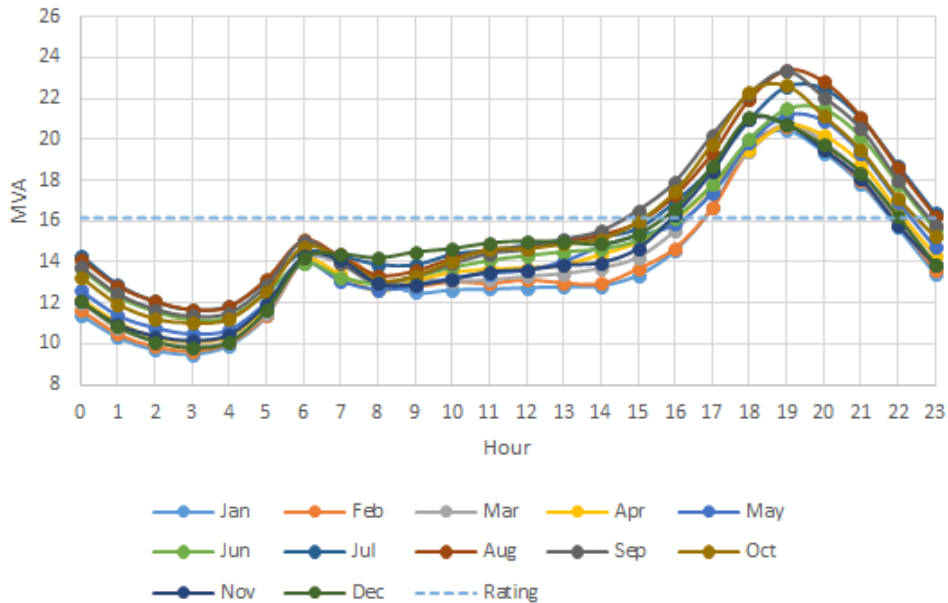
Deferral Opportunity	Equipment	MW Peak	Operational Date	Delivery Months	Delivery Hours	Duration (Hr)	Max # of Days	MWH
Ho’opili Substation	Kaloi 1 Tsf	4.7	Jan 2023	Jan–Dec	1PM–11AM	10	365	21.5
	Kaloi 3 Ckt	0.3	Aug 2023	Aug–Oct	7PM–9PM	2	69	0.4

**Figure F-15: Summary of Contingency Overloads**

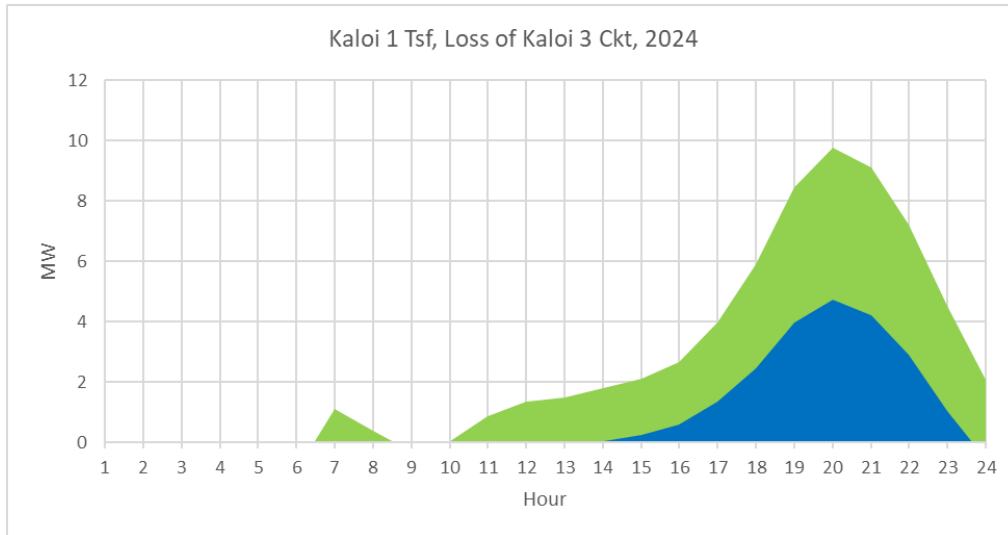
Deferral Opportunity	Equipment	MW Peak	Operational Date	Delivery Months	Delivery Hours	Duration (Hr)	Max # of Days	MWH
Kapolei 4 Circuit Extension	Kapolei 2 Tsf	3.5	Feb 2022	Jan-Dec	5PM-11PM	6	365	11.4
Ho'opili Substation	Ewa Nui 2 Ckt	5.1	Jan 2023	Jan-Dec	11AM-12AM	13	365	30.9
	Kalo 1 Tsf	9.7	Jan 2023	Jan-Dec	6AM-8AM, 9AM-12AM	17	365	62.8
	Kalo 3 Ckt	2.6	Jan 2023	Jan-Dec	5PM-11PM	6	365	8.5
	Kamokila 4 Ckt	1.0	May 2023	Jan-Dec	5PM-10PM	5	226	2.9

Figure F-16 shows the loading of the peak day by month on the Kalo #1 Transformer in the year 2023. Figure F-17 shows the associated grid need for Kalo #1 Transformer. These, along with graphic representation for all other overloads, were identified in the RFP, Appendix J, for NWA services for the Ho'opili Area, dated November 8, 2019.

**Figure F-16: Kalo #1 Transformer Loading – Monthly Peak Day in 2023**



**Figure F-17: Kaloi #1 Transformer Overload**



The most cost-effective T&D project proposed for comparison to an NWA solution is the construction of a new substation site and associated equipment located in the Ho’opili development. This would result in minimal distribution circuit installation costs because of the location of new loads to serve. Estimated costs for this project are approximately \$12.7 million with provisions for up to four 46-12 kV, 10/12.5 MVA distribution transformers to allow for future load growth in the area.

The IGP Soft Launch RFP process resulted in low response from the market. Because of insufficient response to the RFP to meet the performance and operations requirements for either of the deferral opportunities, the Company, in consultation with the Independent Observer, decided not to move forward with the IGP Soft Launch RFP. As a result, the Company is moving forward with the identified traditional solution. As indicated in Hawaiian Electric’s *Ho’opili Area Study* dated 2019, the proposed project will allow for the timely installation of critical infrastructure to the electrical system, which will provide necessary capacity to serve projected loads and provide essential reliable power under contingency conditions.

Although a traditional solution will be initially pursued for the Ho’opili area, future NWA opportunities remain to enable Ho’opili’s growth. The Company will evaluate the viability of a programmatic DER effort for the Ho’opili and East Kapolei area to reduce longer-term needs for distribution upgrades in the area. The Company will reevaluate options as load grows (around 2024 or 2025) and will determine if future NWA opportunities become available. The Company has also recognized the challenge and need of exploring ways to cost-effectively mitigate the impact of large new real estate development loads.

The Company was one of the first, if not the first, to procure for a distribution reliability (back-tie) service nationally and gained valuable experience while proceeding through the Soft Launch process. The Company will continue to improve the IGP process going forward and will conduct future NWA

procurements for distribution opportunity based on lessons learned from the Soft Launch. Some lessons learned that will be applied to the IGP process include the following<sup>49</sup>:

- Leverage the NWA evaluation framework developed by the DPWG to determine opportunities best suited for procurements
- Continue to pursue market solutions to acquire least cost, best fit solutions for customers, but consider tariff and program options to complement procurements
- Continue discussion in examining opportunities to capture multiple services from resources at longer-duration contracts
- Pursue standard form RFP for NWAs and streamline the process for short lead time/near-term needs.

## Expression of Interest for NWA Opportunities

In the years 2022 and 2023, EOIs were issued for three T&D NWA opportunities which were identified as Track 1 opportunities based on the NWA methodology. The objective of the EOIs were to identify interested parties who are able to develop cost competitive utility-scale renewable projects or aggregating DER/EE projects in specific locations to fulfill grid service performance requirements. As part of the EOIs, the performance requirements, net present value (NPV) of the deferral or avoidance cost of the traditional wires solution, and a map of the areas where the NWA projects are required were provided.

The information obtained from responses would help the Company determine if there are viable cost competitive NWA projects, to move forward with issuance of an RFP or alternative means of procurement, subject to approval by the Hawai'i Public Utilities Commission. The following discussions summarizes the opportunities and results.

### Ewa Nui B Transformer NWA

The Company forecasts significant load growth in central O'ahu in the coming years. The load is forecasted to increase by approximately 70 MVA by 2030 triggering overloads beginning in 2026 during a contingency condition. Therefore, the Company has identified a capacity and reliability grid need and issued an EOI in 2/2023 to developers or aggregators who are capable of developing utility-scale renewable projects or aggregating DER/EE in the Central O'ahu area.

The traditional wires solution consists of installing a new 80MVA 138-46kV transformer and associated equipment at Ewa Nui Substation with a new 46kV circuit. This solution is preliminarily estimated to cost \$15.0M.

To address these grid needs, the Company sought capacity (MW) and energy (MWH) annual grid needs shown in Figure F-18 to defer the need for the wires project by five years.

---

<sup>49</sup> March 9, 2020, DPWG Presentation Slides

[https://www.hawaiianelectric.com/documents/clean\\_energy\\_hawaii/integrated\\_grid\\_planning/stakeholder\\_engagement/working\\_groups/soft\\_launch/20200309\\_igp\\_soft\\_launch\\_wg\\_presentation\\_materials.pdf](https://www.hawaiianelectric.com/documents/clean_energy_hawaii/integrated_grid_planning/stakeholder_engagement/working_groups/soft_launch/20200309_igp_soft_launch_wg_presentation_materials.pdf).

**Figure F-18: Annual Grid Needs**

	2026	2027	2028	2029	2030
Capacity (MW)	7.2	9.5	12.2	15.1	16.5
Energy (MWH)	8.5	15.5	31.1	65.0	87.8

This project is intended to defer a T&D solution to provide capacity to the 46 kV system for five years. The NPV of the deferral value is: \$7.0M.

The Company did not receive any responses to this EOI and will be pursuing the traditional wires solution.

### **CEIP 46 Reconductoring NWA**

The Company forecasts significant load growth in west O’ahu from Ewa to Kapolei areas in the coming years. The load is forecasted to increase by approximately 53 MVA by 2030 triggering overloads of existing electrical infrastructure beginning in 2025 during a contingency condition. Therefore, the Company has identified a capacity and reliability grid need and issued an EOI in 2/2023 to developers or aggregators who are capable of developing utility-scale renewable projects or aggregating DER/EE in the Ewa and Kapolei areas of O’ahu.

The traditional wires solution consists of installing approximately 520 ft of new 1500KCM cables parallel to existing cables and reconductoring approximately 1.91 miles of 556 conductor to 795 conductor. This solution is preliminarily estimated to cost \$3.93M.

To address this grid need, the Company sought the aggregate NWA amount of 5.71MW/13.9MWH in 2025 for the expected 30-year lifespan of a wires project to avoid the cost of the wires project. Figure F-19 shows the capacity (MW) and energy (MWH) annual grid needs.

**Figure F-19: Annual Grid Needs**

	2025	2026	2027	2028	2029
Capacity (MW)	5.71	5.71	5.71	5.71	5.71
Energy (MWH)	13.9	13.9	13.9	13.9	13.9

This project is intended to avoid a T&D solution to provide capacity to the 46 kV system. The NPV to avoid the wires project is \$4.57M.

The Company did not receive any responses to this EOI and will be pursuing the traditional wires solution.

### **Kewalo T4 Transformer NWA**

The Company forecasts significant load growth in the Kakaako and Kewalo area in the coming years. The forecasted load growth totals approximately 30 MVA by 2030 triggering normal and contingency overloads of existing electrical infrastructure beginning in 11/2025. Therefore, the Company identified a

capacity and reliability grid need and issued an EOI in 3/2023 to developers or aggregators who may be interested and capable of developing utility-scale renewable projects or aggregating DER/EE in the Kakaako and Kewalo areas of O’ahu.

The traditional wires solution consists of installing a 138-25 kV, 50 MVA transformer and associated equipment at Kewalo Substation and four new 25 kV circuits. The solution is preliminarily estimated to cost \$22M.

To address these grid needs, the Company sought aggregate NWA amounts for two scenarios below. Figure F-20 shows the capacity (MW) and energy (MWH) annual grid needs.

1. 2.0MW/3.3MWH in 2025-2026 to defer the wires project by one year; or
2. 2.0MW/3.3MWH in 2025-2026 and 17.7MW/168.5MWH in 2027 to avoid the need for the wires project.

**Figure F-20: Annual Grid Needs**

	11/2025	2026	2027	2028	2029	2030
Capacity (MW)	2.0	2.0	17.6	17.7	17.7	17.7
Energy (MWH)	3.3	3.3	166.6	168.5	168.1	167.7

The NWA is intended to defer or avoid a T&D solution to provide capacity to the distribution system. The approximate NPV for the two NWA scenarios were:

1. NPV to defer the wires project by one year: \$3.17M.
2. NPV to avoid the wires project: \$25.6M

The Company is currently waiting for responses.